

FEATURES:

- MINIATURE SIZE
- LOW VSWR
- HIGH DIRECTIVITY
- R.F. SHIELDED
- QUALIFIED TO MIL-E-5400 AND MIL-STD-2036

ELECTRICAL CHARACTERISTICS:

Part Number	AX03-0206	AX03-0210	AX03-0220	AX03-0230
Operating Frequency Range	1.000 to 2.000 GHz			
Frequency Sensitivity	± 0.60 dB	± 0.75 dB		
Coupling	6 ± 1.25 dB	10 ± 1.25 dB	20 ± 1.25 dB	30 ± 1.25 dB
True Insertion Loss	1.80 dB max.	0.80 dB max.	0.20 dB max.	
Insertion Loss Excluding Coupled Power	0.20 dB max.		0.15 dB max.	
VSWR-Primary Line	1.15:1 max.	1.10:1 max.		
VSWR-Secondary Line	1.15:1 max.	1.10:1 max.		
Directivity	25 dB min.			
Average Incident Power	50 W			
Average Reflected Power	2 W	5 W	50 W	
Peak Power	3 KW			
Operating Temperature Range	-30°C to 70°C			

Specifications are subject to change for continuous improvement.

MECHANICAL CHARACTERISTICS:

Material: Housing-Alum. 6061T6

- : Connectors-Passivated Stainless Steel
- : Termination-Passivated Stainless Steel Housing

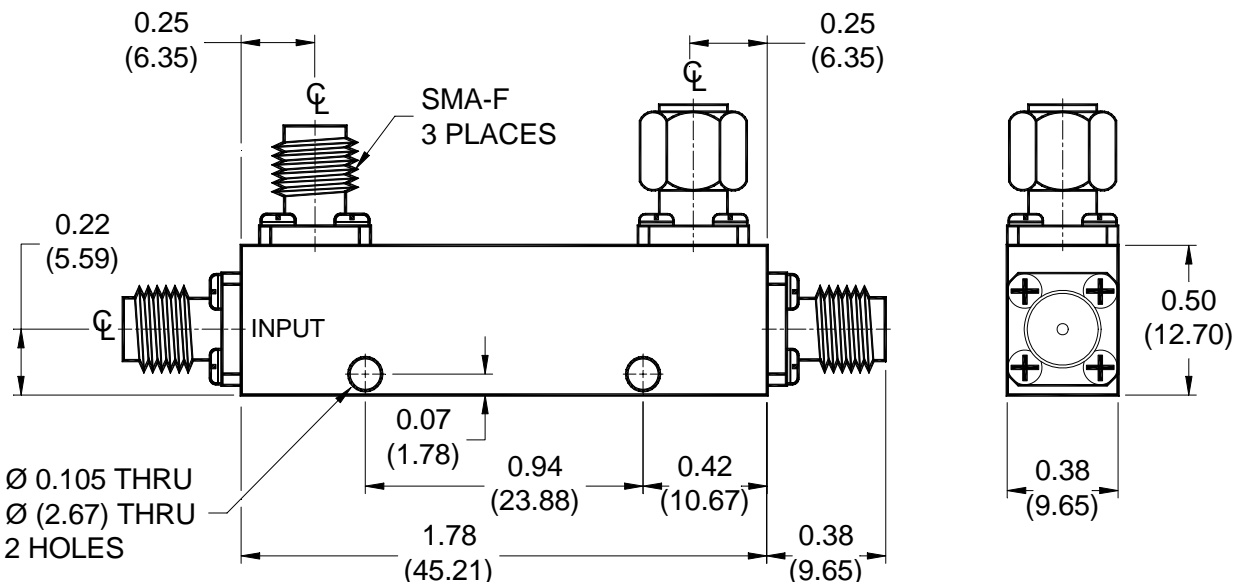

TSI • 2459 46th Avenue, Lachine, (Québec) Canada, H8T 3C9 • Tel.: 514.631.8837

e-mail: info@trackcom-sys.ca

www.trackcom-sys.ca